

MA2

series



Product Segments

- **Industrial Motion**

TiMOTION's MA2 series electric linear actuator was specifically designed for applications that face harsh working environments requiring heavy-duty use and durability. Furthermore, the MA2 has an optional **T-Smart** version. Embedded with a TiMOTION driver board, the MA2 allows for easy integration with different control interfaces, eliminating the need of an external control box.

The MA2 is available in **three** T-Smart alternatives:

1)T-Smart Advanced

The T-Smart Advanced alternative allows for synchronization of up to 8 actuators, as well as accurate position feedback through a variety of options (Hall, Hall-Pot., PWM).

2)T-Smart SAE J1939

This alternative provides seamless integration with CAN bus SAE J1939 interfaces, the standardized communication protocol commonly implemented in off-road vehicles and other industrial applications.

3)T-Smart Modbus

Modbus is a serial communication protocol predominantly used in industrial automation and process control. The T-Smart Modbus alternative can be smoothly incorporated into existing industrial systems.

All T-Smart alternatives are compatible with TiMOTION's software program, **PGMA**, providing the user autonomy to adjust parameters such as speed, stroke limits, soft stop, soft start, and more.

General Features

Max. load	8,000N (push); 4,000N (pull)
Max. speed at max. load	5.1mm/s
Max. speed at no load	52.5mm/s
Retracted length	≥ Stroke + 131mm
IP rating	IP69K
Certificate	UL73, EMC
Stroke	25~1000mm
Output Signals	Adjustable Reed switch, mechanical Pot., NPN Hall sensors
Voltage	12/24/36/48V DC; 12/24/36/48V DC (thermal switch)
Operational temperature range	-40°C~+85°C
Operational temperature range at full performance	+5°C~+45°C
Manual drive	

Drawing

Standard Dimensions
(mm)

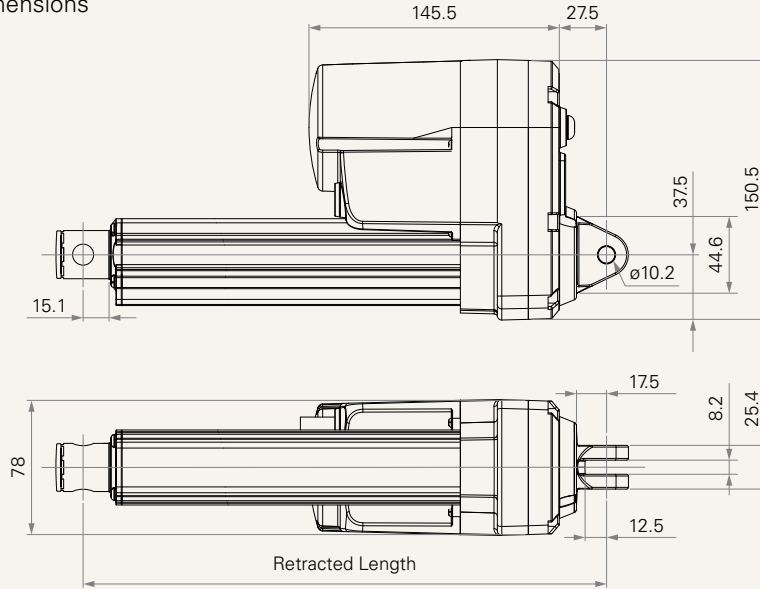

Load and Speed

CODE	Load (N)		Self Locking Force (N) Mechanical Brake	Duty Cycle	Typical Current (A)		Typical Speed (mm/s)		Typical Current (A)		Typical Speed (mm/s)	
	Push	Pull			No Load	With Load	No Load	With Load	No Load	With Load	No Load	With Load
					24VDC				12VDC			
Motor Speed (5200RPM)												
F	1000	1000	1300	25%	2.7	6.8	52.5	44.2	5.2	13.5	52.5	42.0
G	2000	2000	2600	25%	2.4	6.7	25.5	21.8	4.3	12.6	25.5	20.4
H	4000	4000	5200	25%	2.3	6.9	13.2	11.0	4.2	13.0	13.2	10.9
J	6000	4000	8000	25%	2.0	5.8	6.6	5.8	3.8	11.0	6.6	5.5
K	8000	4000	8000	10%	2.0	6.9	6.6	5.5	3.8	13.0	6.6	5.1

Note

- #B, C, D, E are only available in Type #N_Normal.
- Please refer to the approved drawing for the final authentic value.
- The current & speed in table are tested with 24V DC motor. With a 12V DC motor, the current is approximately twice the current measured in 24V DC. With a 36V DC motor, the current is approximately two-thirds the current measured in 24V DC. With a 48V DC motor, the current is approximately half the current measured in 24V DC. Speed will be similar for all the voltages.
- The current & speed in table are tested when the actuator is extending under push load.
- The current & speed in table and diagram are tested with a stable 24V DC power supply.
- Without load, noise level ≤ 78 dBA (by TIMOTION test standard, ambient noise level ≤ 36 dBA)
- Standard stroke: Min. 25 mm, Max. please refer to the table below.

CODE	Load (N)	Max Stroke (mm)
F, B	≤ 1000	1000
G, C	≤ 2000	800
H, J, D, E	≤ 6000	600
K	≤ 8000	200

* Max. stroke with mechanical Pot: 570mm.

Performance Data (24V DC Motor)

Motor Speed (5200RPM)

Speed vs. Load

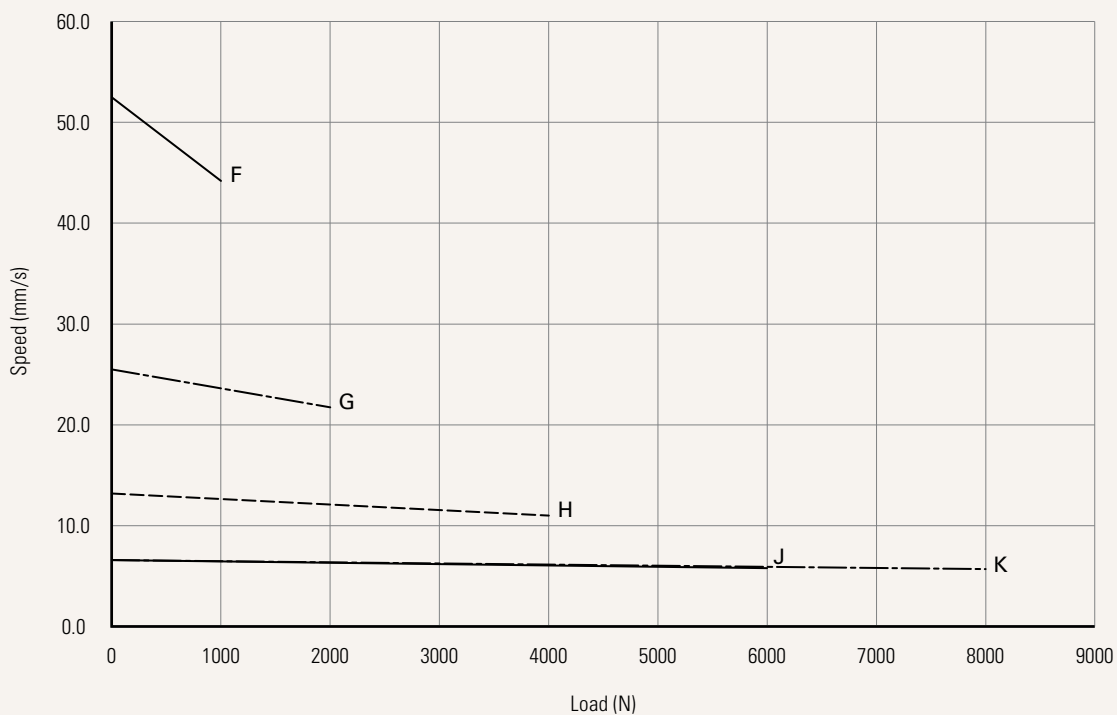

Current vs. Load

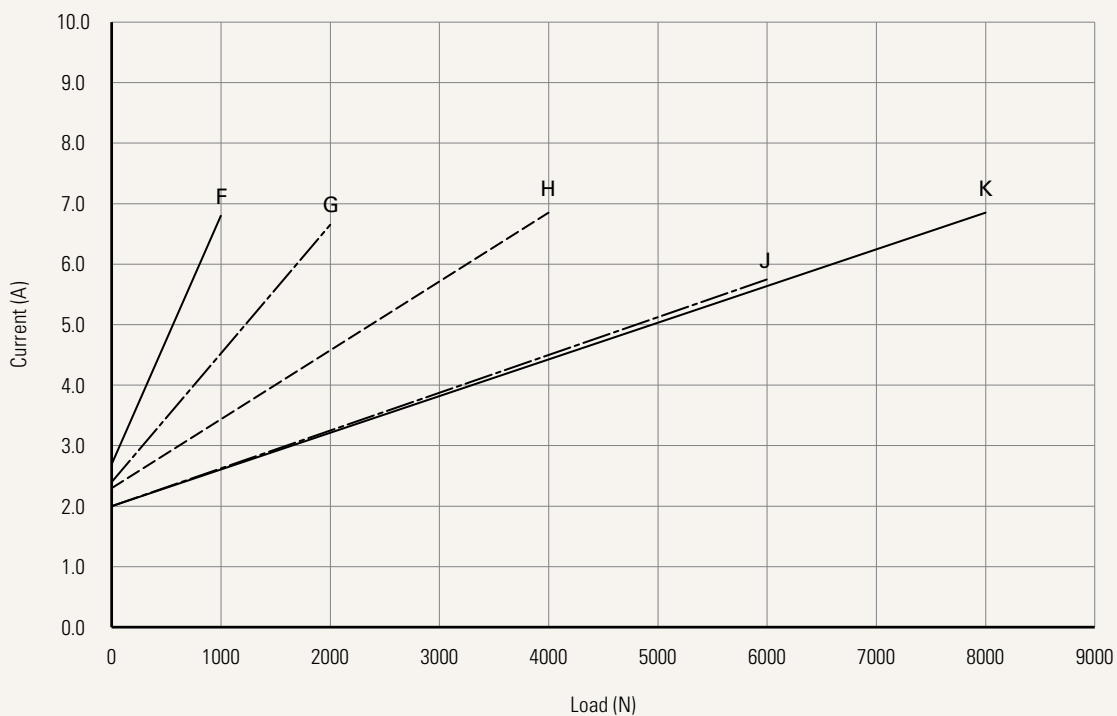

Performance Data (12V DC Motor)

Motor Speed (5200RPM)

Speed vs. Load

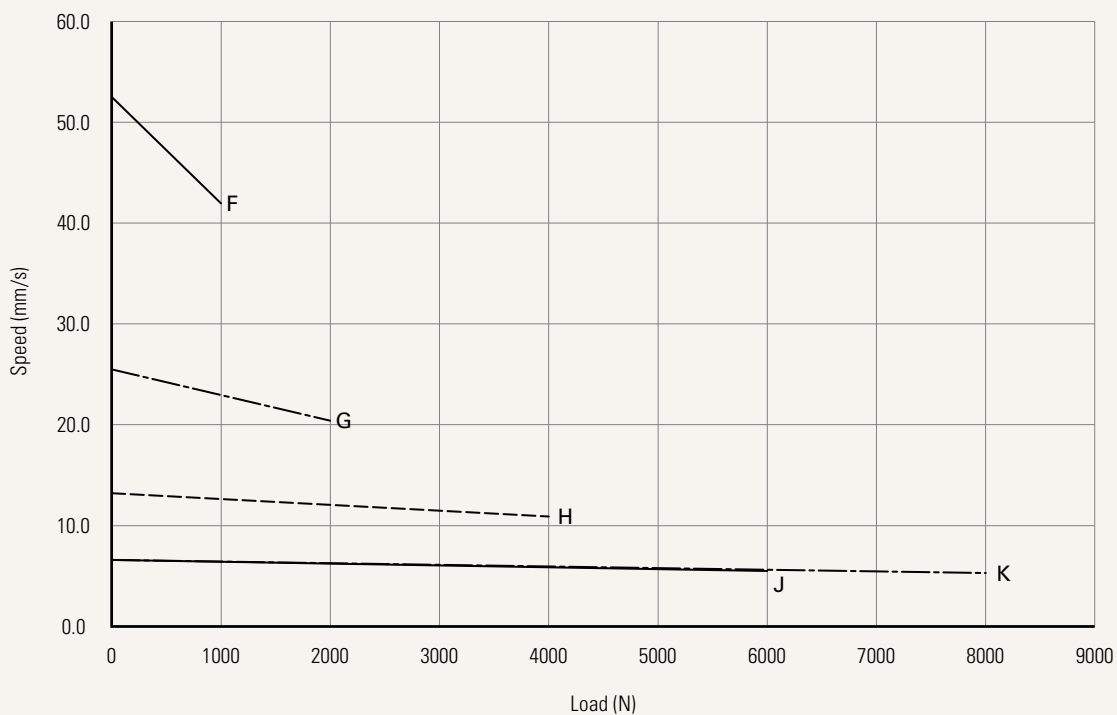

Current vs. Load

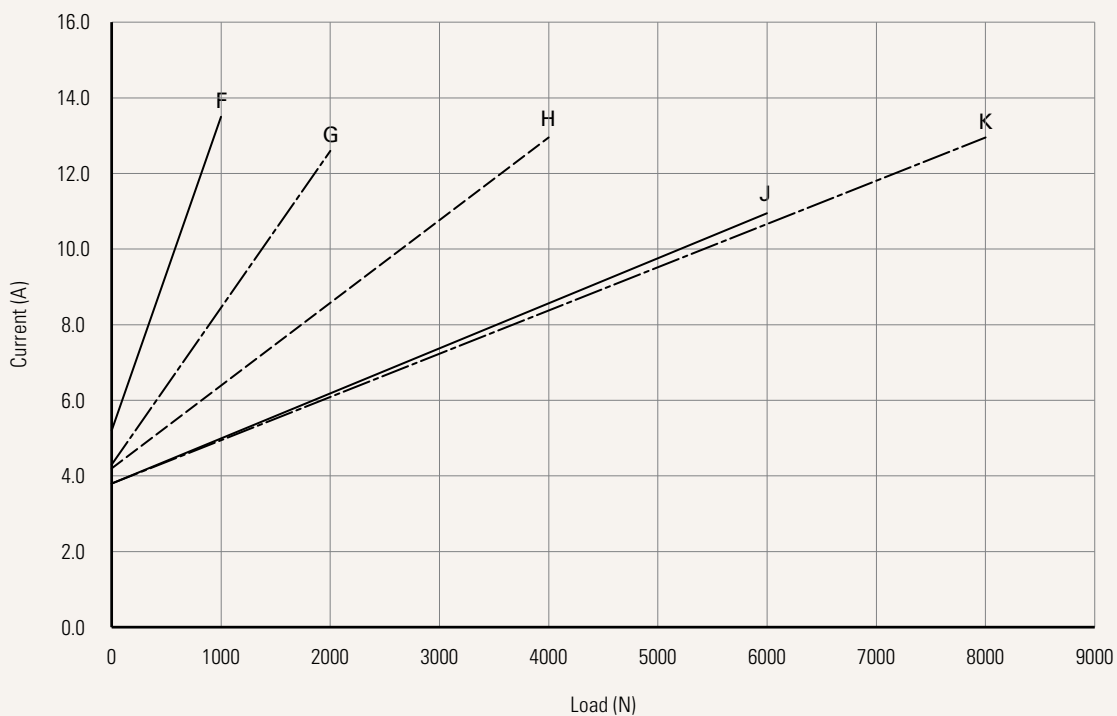

Type	N = Normal	T = T-Smart		
Voltage	1 = 12V DC 2 = 24V DC	3 = 36V DC 4 = 48V DC	5 = 24V DC, thermal switch 6 = 12V DC, thermal switch	7 = 36V DC, thermal switch 8 = 48V DC, thermal switch
Load and Speed	See page 2			
Stroke (mm)	See page 2			
Retracted Length (mm)	See page 5			
Rear Attachment (mm)	1 = Aluminum, U clevis, slot 8.2, depth 12.5, hole 10.2 2 = Aluminum, U clevis, slot 8.2, depth 15.0, hole 10.2	3 = Aluminum, U clevis, slot 8.2, depth 15.0, hole 12.8 4 = Aluminum, U clevis, slot 8.2, depth 15.0, hole 12.2		
See page 5				
Front Attachment (mm)	1 = Steel, inner tube with punching hole and seal plug, hole 10.2 2 = Steel, inner tube with punching hole and seal plug, hole 12.2 3 = Steel, inner tube with punching hole and seal plug, hole 12.8	4 = Aluminum, U clevis, slot 8.2, depth 15.0, hole 10.2 5 = Aluminum, U clevis, slot 8.2, depth 15.0, hole 12.2 6 = Aluminum, U clevis, slot 8.2, depth 15.0, hole 12.8 K = Rod end bearing, hole 12.8		
See page 6				
Direction of Rear Attachment (Counterclockwise)	1 = 0°	3 = 90°		
See page 6				
Function of Limit Switches	1 = Two micro switches cut off the actuator at EOS 2 = Two micro switches cut off the actuator at EOS + third one in between sends signal	3 = Two micro switches send signal at EOS 6 = Two micro switches cut off the actuator and send signal at EOS (signal type: normally open)		
Adjustable Reed Switch	0 = Without	1 = Reed switch*1	2 = Reed switch*2	
Output Signal	0 = Without	1 = Mechanical pot.	N = NPN Hall sensor*2	
IP Rating	1 = Without 2 = IP54	3 = IP66 6 = IP66M	8 = IP69K	
Cable Exit	1 = Single cable 3 = 3 sockets with extension cable (P1, P2, P3) (T-Smart dedicated option)	T = Direct cable out, 1+1 type: Military connector (A1) + Molex 6P connector (P2) (T-Smart dedicated option)		
See page 7-9				
A1 / P1 Connector (mm)	01 = Tinned leads, unsheathed wire 50, stripped wire 10			
See page 6				
A1 / P1 Cable Length (mm)	0500 = 500	1000 = 1000	2000 = 2000	3000 = 3000
P2 Connector (mm)	00 = Without 01 = Tinned leads, unsheathed wire 50, stripped wire 10 (T-Smart dedicated option)	0P = Rubber seal plug (T-Smart dedicated option)		
P2 Cable Length (mm)	0000 = Without	1000 = 1000 (T-Smart dedicated option)	2000 = 2000 (T-Smart dedicated option)	
P3 Connector (mm)	00 = Without	01 = Tinned leads, unsheathed wire 50, stripped wire 10 (T-Smart dedicated option)		
P3 Cable Length (mm)	0000 = Without	1000 = 1000 (T-Smart dedicated option)	2000 = 2000 (T-Smart dedicated option)	
Alternative	N = Normal T = Advanced J = SAE J1939 (J1939 default, transmission rate 250Kbps, proposal#PF22018)	K = SAE J1939 (transmission rate 500Kbps, proposal#DS23021) M = Modbus (proposal# PF22082)		
Packaging (mm²)	0 = Sample packaging C = Standard package, US fumigated pallet (1219*1016) 1 = Standard package, EU fumigated pallet (1200*800) 2 = Standard package, EU fumigated pallet (1500*800)	E = Standard package, US plywood pallet (1219*1016) 5 = Standard package, EU plywood pallet (1200*800) 6 = Standard package, EU plywood pallet (1500*800)		

Retracted Length (mm)

1. Calculate $A+B+C = Y$
2. Retracted length needs to \geq Stroke + Y

A.

Front Attachment	Rear Attachment	
	1	2, 3, 4
1, 2, 3	+131	+134
4, 5, 6	+161	+164
K	+178	+181

C.

Output Signal	
0, N, P	-
1	+20

B.

Stroke (mm)	Load & Speed Type (N)
	B, C, D, E, F, G, H, J, K
25~150	-
151~200	-
201~250	+10
251~300	+20
301~350	+30
351~400	+40
401~450	+50
451~500	+60
501~550	+70
551~600	+80
601~650	+90
651~700	+100
701~750	+110
751~800	+120
801~850	+130
851~900	+140
901~950	+150
951~1000	+160

Rear Attachment (mm)

1 = Aluminum, U clevis, slot 8.2, depth 12.5, hole 10.2

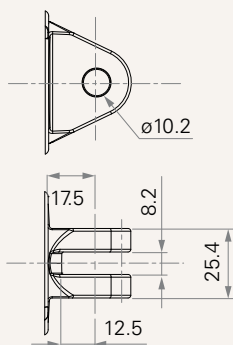

2 = Aluminum, U clevis, slot 8.2, depth 15.0, hole 10.2

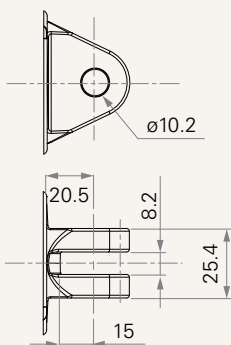

3 = Aluminum, U clevis, slot 8.2, depth 15.0, hole 12.8

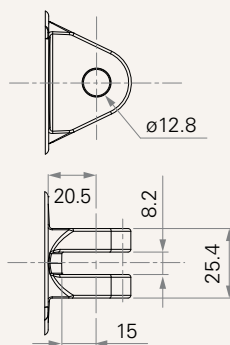

4 = Aluminum, U clevis, slot 8.2, depth 15.0, hole 12.2

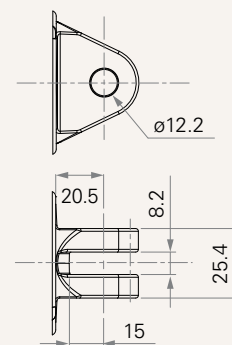

Front Attachment (mm)

1 = Steel, inner tube with punching hole and seal plug, hole 10.2

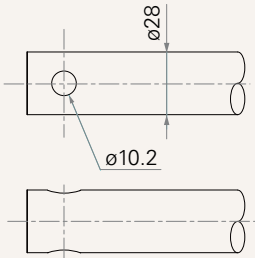

2 = Steel, inner tube with punching hole and seal plug, hole 12.2

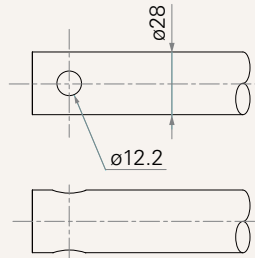

3 = Steel, inner tube with punching hole and seal plug, hole 12.8

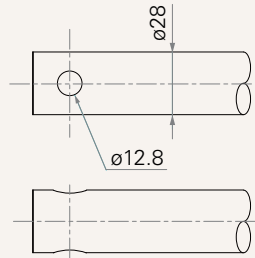

4 = Aluminum, U clevis, slot 8.2, depth 15.0, hole 10.2

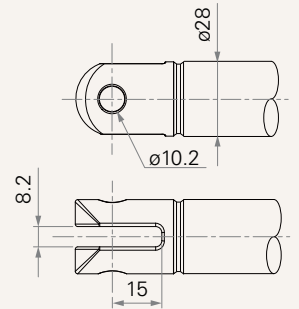

5 = Aluminum, U clevis, slot 8.2, depth 15.0, hole 12.2

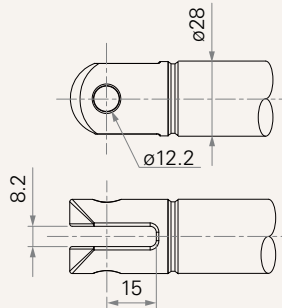

6 = Aluminum, U clevis, slot 8.2, depth 15.0, hole 12.8

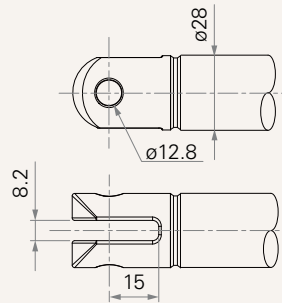

K = Rod end bearing, hole 12.8

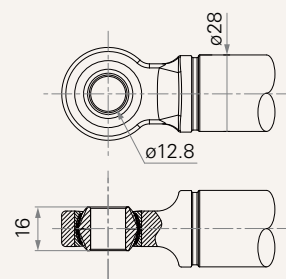

Direction of Rear Attachment (Counterclockwise)

1 = 0°

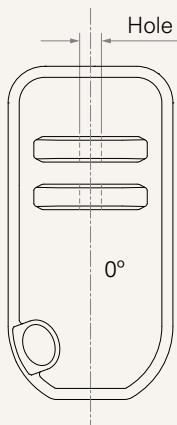

3 = 90°

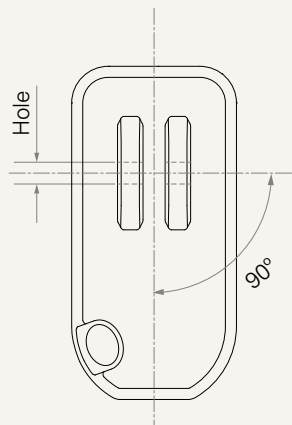

Connector (mm)

01 = Tinned leads, unsheathed wire
50, stripped wire 10

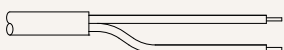

Wire Definition

#N_Normal

Port	Wire Color	AWG	Output Signal		
			0. Without	1. Mechanical pot.	N. NPN Hall*2
A1	● BK	20	-	-	GND
	● BU	20	-	-	-
	○ WH	20	-	-	S1
	● RD	20	-	-	Vcc
	● RD	14	EXT+	EXT+	EXT+
	● BK	14	RET+	RET+	RET+
	● RD	20	-	pin 1	-
	○ WH	20	-	pin 2	-
	● BK	20	-	pin 3	-

0 = Without

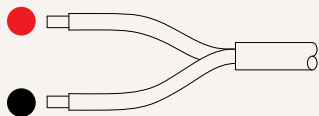

1 = Mechanical pot.

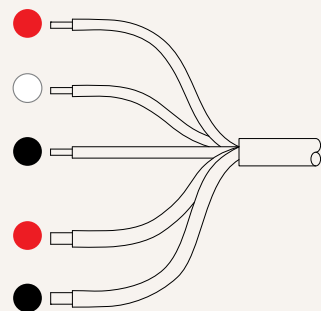

N = NPN Hall sensor*2

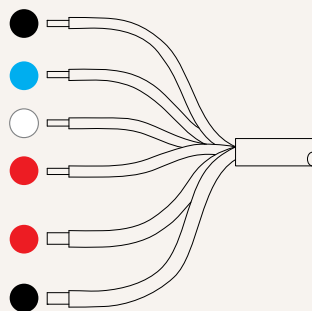

Wire Definition

#T_T-Smart

3 sockets with extension cable (P1, P2, P3) (T-Smart dedicated option)

Port	Wire Color	AWG	Signal
P1	● RD	14	+Vcc
	● BK	14	Power ground
P2	● RD	20	For programming or wireless accessories.
	○ WH	20	
	● BU	20	
	● BK	20	
	● BN	20	
	● GY	20	
P3	● BN	20	Ctrl - Extend
	● GY	20	Ctrl - Retract
	● OG	20	EOS-extended
	● YE	20	EOS-retracted
	○ WH	20	Hall-Pot./ Hall A/ Commu. A
	● BU	20	PWM/ Hall B/ Commu. B
	● RD	20	Vaux.
	● BK	20	Signal ground

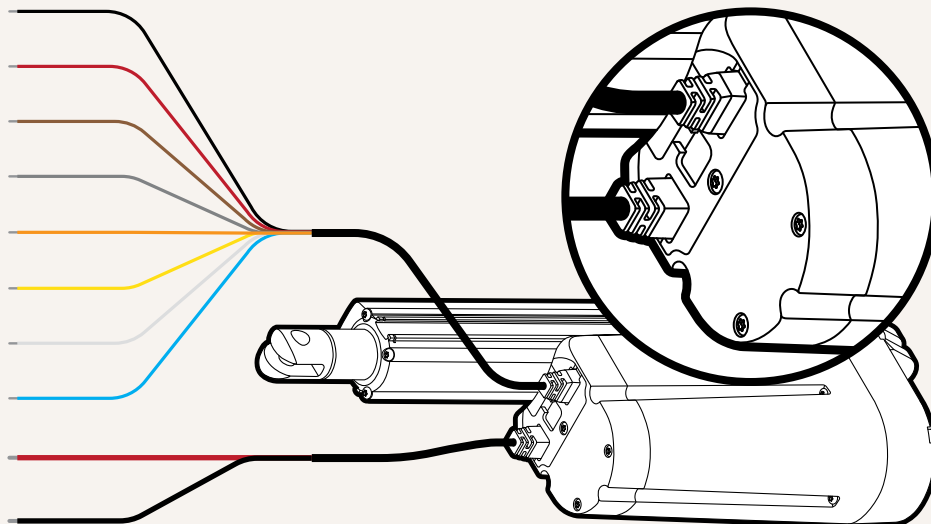

Wire Definition

#T_T-Smart

Direct cable out, 1+1 type: Military connector (A1) + Molex 6P connector (P2) (T-Smart dedicated option)

Port	Wire Color	AWG	Signal
A1	● RD	14	+Vcc
	● BK	14	Power ground
	● BN	20	Ctrl - Extend
	● GY	20	Ctrl - Retract
	● OG	20	EOS-extended
	● YE	20	EOS-retracted
	○ WH	20	Hall-Pot./ Hall A/ Commu. A
	● BU	20	PWM/ Hall B/ Commu. B
	● BK	20	Signal ground
	P2	● RD	20
○ WH		20	
● BU		20	
● BK		20	
● BN		20	
● GY		20	

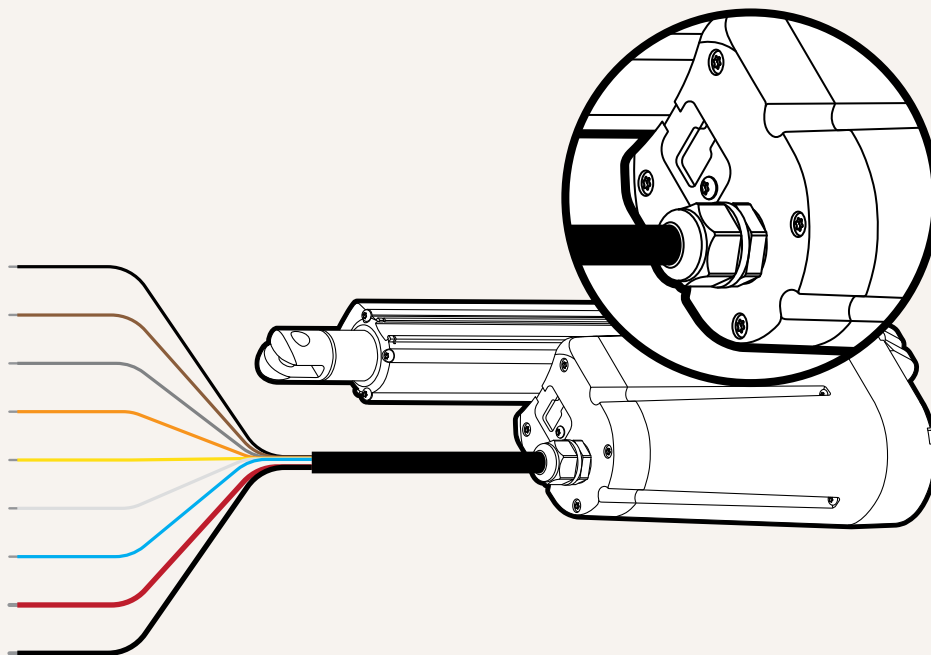

Terms of Use

The user is responsible for determining the suitability of TiMOTION products for a specific application. TiMOTION products are subject to change without prior notice.